

SANTOPRENE GASKET

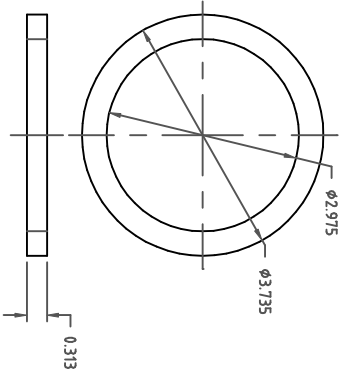

POLYPROPYLENE NUT

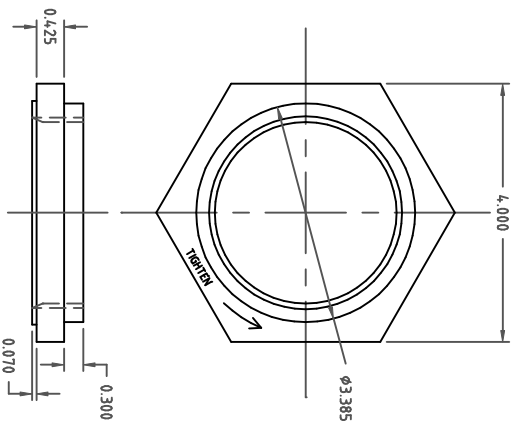

10507

A

ASSEMBLY

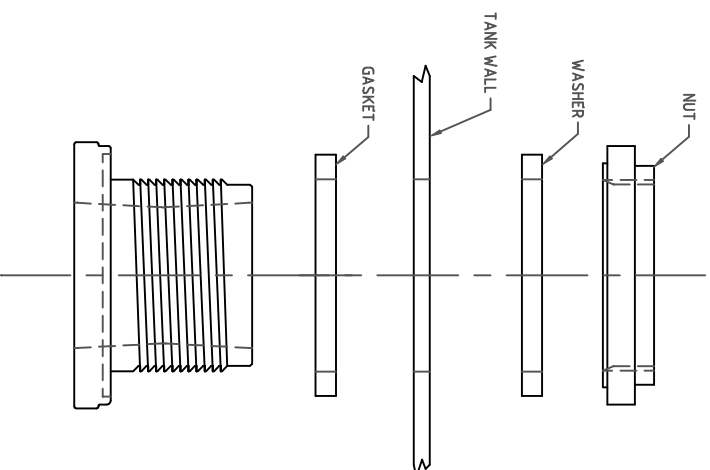

POLYPROPYLENE BODY

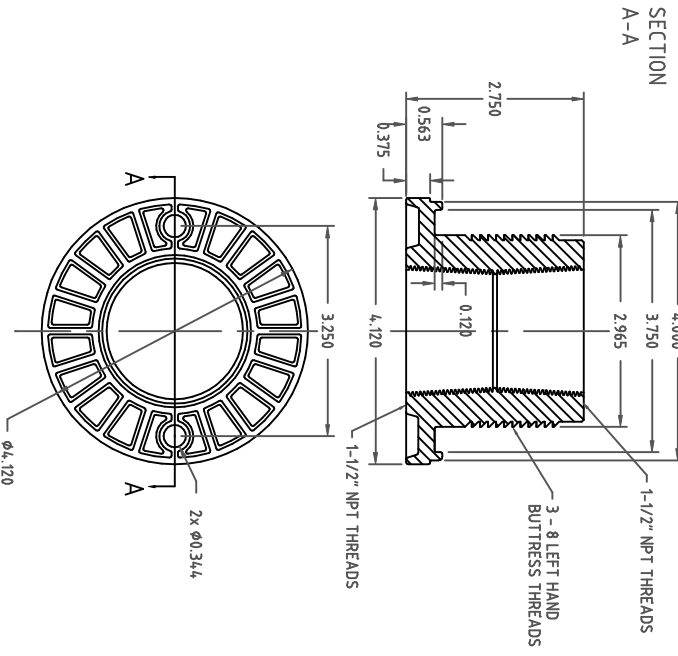

POLYPROPYLENE WASHER

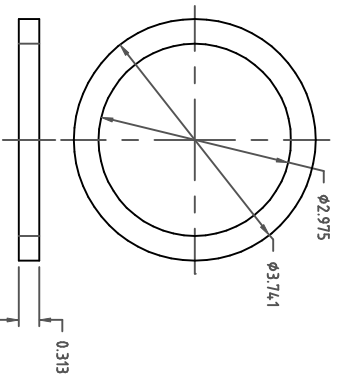

MATERIAL

DHJ/12/14/04

APPRD. / DATE

GWC 4/13/07

THIRD ANGLE PROJECTION

ANSI 14.5M

NOTES:

STANDARD 1 1/2" BULKHEAD

**INJECTION MOLDING**

A DIVISION OF DEN HARTOG INDUSTRIES, INC.  
4010 HOSPERS DRIVE S., BOX 425, HOSPERS, IOWA 51238-0425

CLIENT / DESCRIPTION

SCALE

NONE

PART NO.

10507

REV	DESCRIPTION	DATE	APPRD
A	UPDATE LOGO AND TOL. CCN 1296	4/13/07	GWC

ALL DIMENSIONS ARE IN DECIMAL INCHES  
TOLERANCES UNLESS OTHERWISE SPECIFIED

.XXX +/- .016"  
.XX +/- .032"  
.X +/- .062"

DRAWN / DATE

DHJ/12/14/04

APPRD. / DATE

GWC 4/13/07

THIRD ANGLE PROJECTION

ANSI 14.5M

